

# **Semi- automatic tire changer**

# **Operating instruction**

## Preface:

Thank you for buying our semi-automatic tyre changer. It is the best quality. In order to proper operation and extended the lifetime, Pls read the instruction for each operation section carefully. The data of semi-automatic tyre changer:

## The data of semi- automatic tyre changer:

Provide the “complete product code” and the” model of semi-automatic tyre changer”, so that we can provide you the technical services and required parts betterly .At the same time, easy to operate the machine as technical parameters .If the data in the specification is inconsistent with the label, please refer to the label.

This manual is an indispensable part for machine operation before using the machine, you should read each part of the manual carefully, The operation safety and maintenance parts are necessity.



Save this manual for future using!

## 1. Description of equipment



- |                         |                        |                               |
|-------------------------|------------------------|-------------------------------|
| G ) clamp jaw           | P) column              | U) pedal control bead breaker |
| I ) working head        | Q) air connection head | V) pedal control clamp        |
| L) inflation inlet      | R) bead breaker        | Z) pedal control turntable    |
| M) operation arm        | S) rubber pad          | Y) turntable                  |
| N) horizontal swing arm | T) crown bar           | K) locking handle             |
| A) press tire block     | B) press tire roller   |                               |

**PIC.1**

## 2. General description

### 2.1 Operation instruction

- The semi-automatic tyre changer is designed to facilitate to mount and demount the tires which

the rim sizes is from 9 "to 21" and the maximum diameter of 1,070 mm.



**Operation against instruction is prohibited.**

- The manufacturer shall not be liable for damage resulting from non-compliance with the instructions.

## 2.2 Safety operation rule



**The semi-automatic tyre changer must be operated by trained personnel.**

- The manufacturer shall not be liable for any damage caused by modification of the machine without the manufacturer's approval.
- Manufacturers will immediately discontinue their safety commitments if the user breaches safety rules and causes damage of the machine's safety devices.
- If there is any damage to the safety warning sign during the whole process, the customer can contact the manufacturer according to the icon on page 3 to replace the damaging icon as soon as possible.

## 3、 Transport

- The semi-automatic tyre changer must be transported with the original packaging. Place as indicated on the packing box.
- Move the packed machine by a forklift truck with corresponding lifting capacity. Refer to figure 3 for the forklift insertion direction

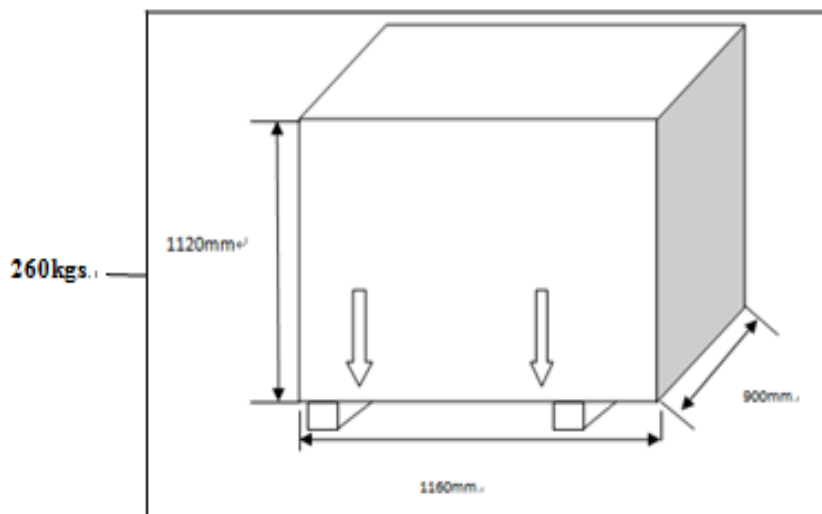

**PIC.3** ↵

## 4、 Open package operation

- Open protective boxes and plastic bags.
- Refer to figure 1 to check whether the machine surface is intact and the parts are

missing and damaging.

- If any problem is found, please do not use the machine and contact the supplier immediately.

## 5、 Installation instruction

### 5.1 Space required

The installation position of the machine must meet the standard of safe working.

- The semi-automatic tyre changer should be placed near the main power supply and compressed air system.
- The minimum space of the installation position shall not be lower than the space that be shown in figure 4 and figure 4/A to ensure normal operation without any restriction.
- If the machine is installed outdoors, a protective shelter must be built.



**The semi-automatic tyre changer is prohibited to use in explosive gas**

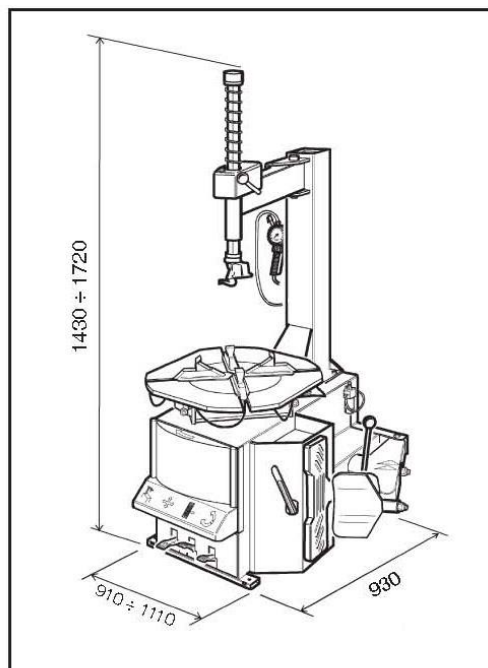

**PIC.4**

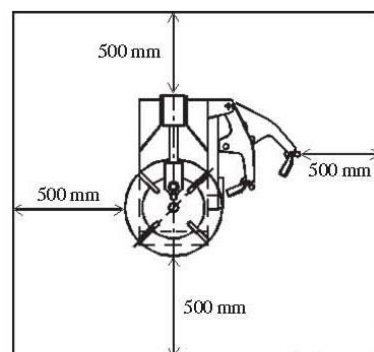

**PIC.4/A**

### 5. 2 Installation of components

- Unscrew the fixed screws on the packing wooden pallet and place the semi-automatic tyre

changer on the ground.

- As shown in figure 5/a, unscrew 6 screws from the box body and install the vertical column at the designated position . Tighten the screws.

Note: for semi-automatic tyre changer, the following three operations are not required:

- Remove pin shaft, nut, washer and adjusting spacer from horizontal swing arm.
- Apply lube to the support on horizontal swing arm. Insert adjustment spacer to prevent friction of horizontal swing arm
- Place the horizontal swing arm on the vertical column, insert the pin shaft and tighten it with the nut and washer.

Note: before connecting all power , check that the installation status of the machine is consistent with the installation requirements of the machine.

- Connect the machine to the compressed air system.(as shown in figure 5/c)
- Step on the pedal to control the bead breaker and the piston rod of cylinder can be extended.(as shown in figure 5/d)

- Install the tire pressure device as shown in figure 5/e.

- insert tire pressure device to bearing, insert the screw hole, not to tighten with the nut or the wrench.
- The piston rod of cylinder through the rotation hole in the pressure device.

- Screw on the nut, but don't tighten it.

- place the spring at the specified point

- Tighten the screws on the tire pressure device as shown in figure 5/f.
- Tighten the nut on the piston rod of the cylinder as shown in figure 5/g.

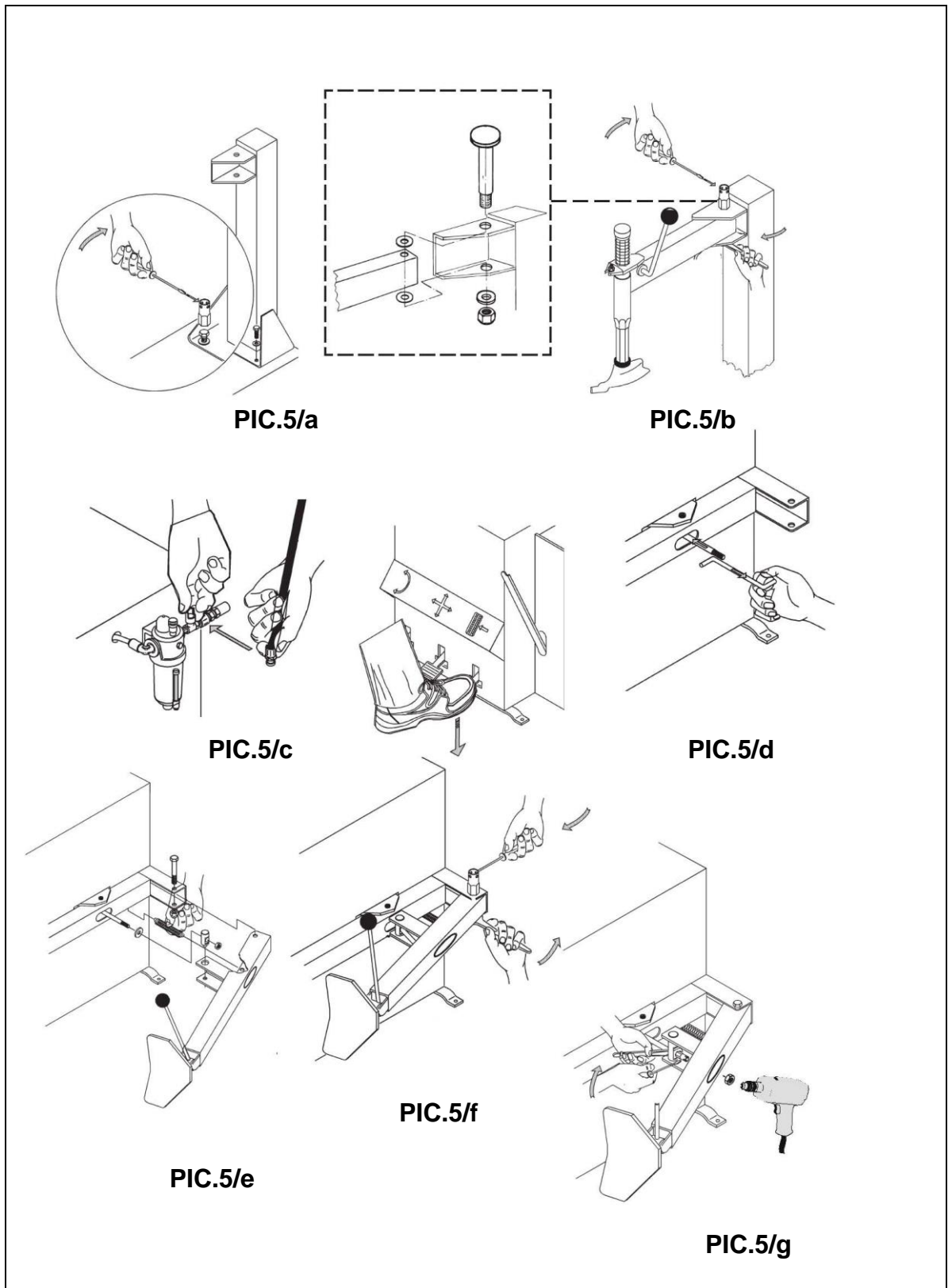

**PIC.5**

### 5.3 commissioning



**Before the machine is turned on, make sure the user's voltage and air pressure are consistent with the machine's requirements.**

When the operating voltage of the machine needs to be changed, the terminal board can be adjusted properly.(refer to part 14 circuit diagram)



**The electrical system must be operated by a professional.**

- The compressed air system is connected to the machine by a pipe joint (Q) on the oil-water separator beside of the box .
- When connecting the circuit of the machine, the circuit must be equipped with safety fuse, grounding wire and must be installed with 30mA automatic circuit breaker.

Note: the power plug of the tyre changer shall be prepared by the customer. The rated current of the power plug shall not be lower than 16A, at the same time meet the voltage of the machine.

## 5.4 Debugging machine

- When the pedal (Z) is stepped on, the turntable (Y) should turn clockwise.
- When the pedal is raised, the turntable should turn counterclockwise.

Note: if the turntable is opposite to the specified rotation direction, switch the two wires of the three-phase plug.

- When the pedal (U) is stepped on, the pressure tyre device (R) will start ; When the pedal is released, the tire pressure device returns to its original position.

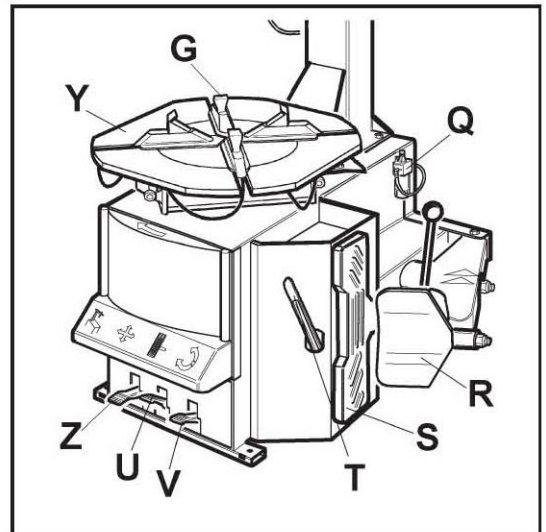

- When the pedal (V) is stepped on, four clamp jaws will open (G); step on the pedal again and the clamp jaws are closed.

**Pic.6**



## Adjust the jaw position of turntable

- The clamps of tyre changer have been adjusted to the central position before leave factory, the clamp rim from outside size is from 9 "to 19".inside size is from 13 "to 25".
- If you want to demount the larger or smaller rim, you can adjust the position of the four clamps, as shown in figure 6/b.

Adjustment range:

clamp rim outside size is from the smallest 9 "-19" to the largest 11 "-21".

clamp rim inside size is from the smallest 13 "-23" to the largest 14 "-25".

The operation is as follows:

- use universal wrench unscrew the screw (1)
- mobile clamp jaw (2) and slider (3), the position corresponding to one of the screw hole of the lock size
- tighten screw, universal wrench torque must be 72 N.m.

Note: the corresponding positions of the four clamps should be ensured when the above adjustment is carried out.

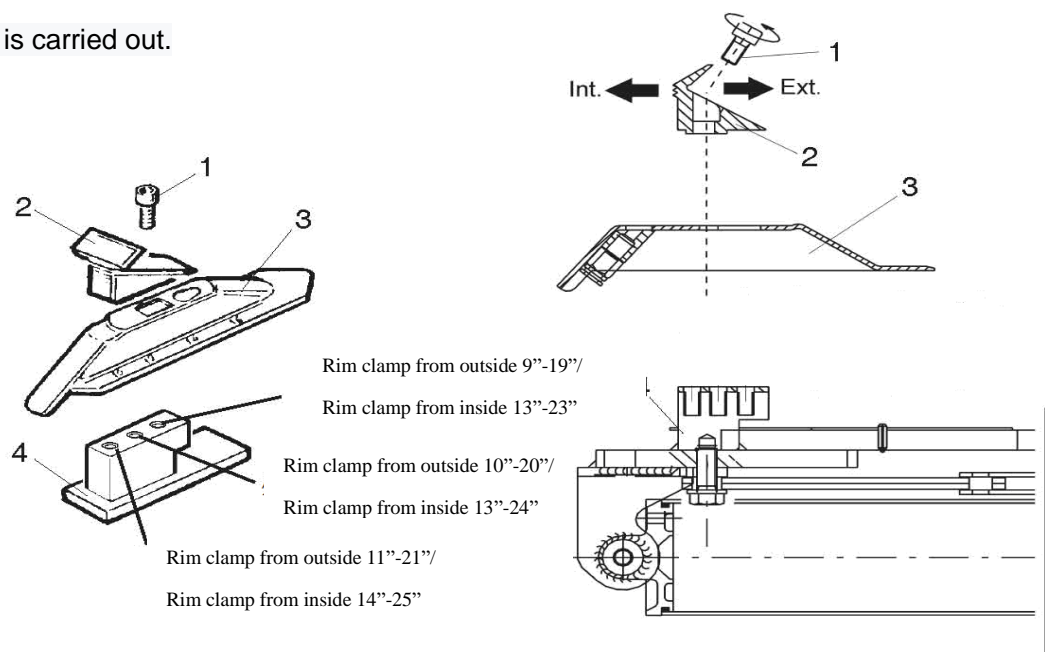

**Pic.6/b**

## 6、 Operation



**Please read the instruction manual carefully and note before operating the machine.**

The operation of semi-automatic tyre changer is divided into the following three parts:

breaking the bead /demount tire /mount tire



**Discharge all air from the tire and remove the balance lead from the tire.**

Matters need attention:

- More and more motorcycle rims are made from special materials such as aluminum magnesium alloys and carbon fiber, In order to lock into this kind of rim , must use special repair tool of the motorcycle tire.
- To avoid damage, The maximum pressure limit of working plate is 5bar.

## 6.1 Breaking the bead



**You have to be very careful when you are operating bead breaker. When the pedal is operated, the breaker arm will swing rapidly and forcefully, and any object within the movable range of the breaker arm is at risk of being crushed.**

- Check the tire to see if it has emptied the gas. If not, empty the gas
- Please close the clamp jaws of the turntable.



**Do not place your hand on the side wall of the tire during operation of the turntable.**

**The clamp may be pressed to your hand when it is open**

- Lean against the tire on the rubber pad (S) on the right side of the automatic tyre changer.
- Press the bead breaker closer to the edge of the rim 1cm (figure 8).It should be noted that the bead breaker should be placed on the tire instead of the rim.
- Step on the pedal (U) and the pressure device is started. Release the pedal when the bead breaker completes the operation or the rim is off.
- Gently rotate the tire and repeat in the rest of the tire until the flange is completely off the rim.  
Repeat on the other side of the tire.

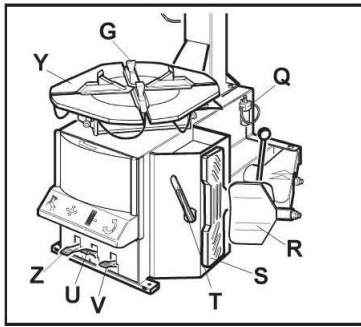

PIC. 7

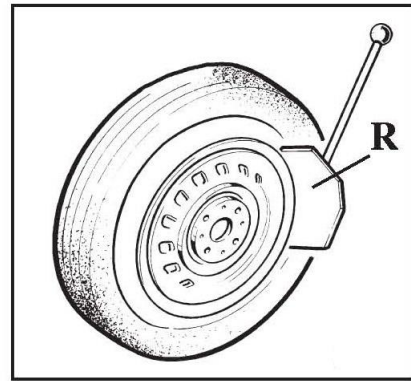

PIC. 8

## 6. 2 Demount tire



**Before any operation, check to see if the tire is out of air. And ensure that the balance lead has been removed from the rim..**

**Apply special lubrication to the rim.**



**Failure to apply lubricant may result in wheel rim damage.**



**Do not put your hand under the tire when you lock the rim. To properly lock the tires, place tire in the center of the turntable.**

**Clamp the rim outside between 10 and 20 inches**

- Step the pedal (V) to the central position and locate the clamp (Y) according to the reference scale of the turntable.
- Place the tire on the clamp so that the rim is near the lowest part of the clamp and step on the pedal (V) to the bottom.

**Clamp the rim inside between 13 and 24 inches**

- Make the clamp (G) closed completely.
- Place the tire on the clamps and step the pedal V to clamp the rim.



**Make sure that the rim is firmly fixed to the clamps.**



**Don't put your hands on the wheel: if you put your hands between rim and mounting head, it may getting hurt when column return to its original position..**

- Lower the operating arm (M) until the dismounting head is supported on the rim edge and locked with the locking handle (K). In the process, the operating arm is locked in a fixed position in the vertical direction, and the working head is moved to 2mm above the rim.

**Note:** Once the operating arm is locked in the vertical direction, the working head must be manually removed from the rim (approximately 2mm) with the manual wheel on the left side of the horizontal swing arm.

- With the crowbar T interested between the bead and the front section of mounting head I, move the tire bead over the mounting head I with crowbar T(see pic.10).

**Note:** In order to avoid damaging the inner tube, if there is one, it should be 10cm to the right of the mounting head I about the above operation.

- While the crowbar in this position, rotate the turntable Y clockwise by pressing down on pedal Z until the tire is completely separated from the wheel rim.



Keep your hands and body as far away as possible from the moving parts when operating the machine, to avoid getting hurt.



Necklaces, bracelets, loose-fitting clothing, or external items can cause personal injury to the operator if they are close to the rotating parts.

- Remove the inner tube if there is one. Repeat the same operation for the other bead.

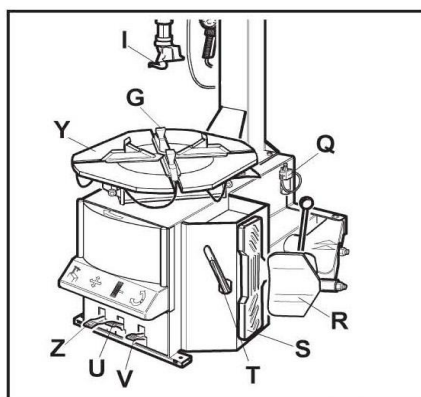

**Pic.9**

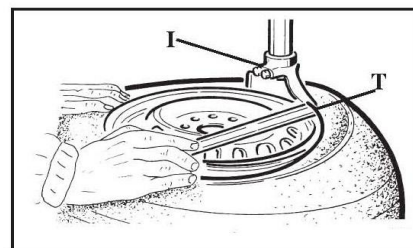

**Pic.10**

## 6. 3 tire mounting



**Note:** To avoid explosion in inflating, it is important to check the tire and n. Before mounting the tire, pay attention to the following points:

- Don't mount the tire if the outside of tire is damaged.
- Check whether the rim is dented or deformed. In particular, there will be small cracks in the rims of alloy wheels, which cannot be seen with naked eyes, that will damage the durability of wheel, so there will also be risks in inflating process.
- Make sure that the wheel rim and tire are of the same size. If you can't make sure of it, don't mount the tire.

- Lubricate the tire beads with special grease in order to avoid damaging them and to facilitate the mounting operations.



**Don't put your hands between tire and clamps in operating clamps, avoiding hands injury**

**Note:** When working with the rims of the same size, it is not necessary always to lock and unlock the mounting bar, just move away and return to its original position about horizontal operating arm.



**Don't put your hands on the wheel: if you put your hands between rim and mounting head, it may getting hurt when operating arm return to its original position.**

- Move the tire so that the bead passes below the front section of the mounting head is brought up against the edge of the rear section of the mounting head itself.
- Keep the tire bead pursed down into the wheel rim channel with your hands. Step pedal M to rotate the turntable clockwise. Continue until you have covered the entire circumference of the wheel rim.



**Keep your hands and body as far as away from the operating arm when rotating the turntable, avoiding body injury.**

- Insert the inner tube, if there is one. Repeat the above operation for the other side of bead.

**Note:** Turntable is always rotating clockwise during mounting and demounting process, unless the machine is something wrong or operating mistakenly, it may rotate anticlockwise.

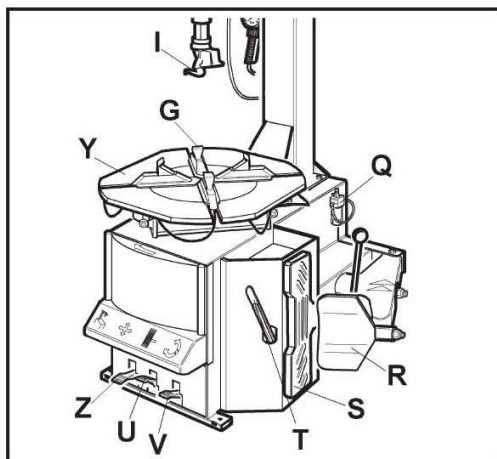

**Pic.11**

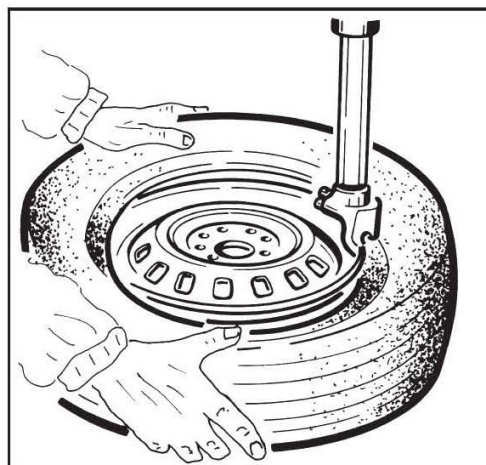

**Pic. 12**

## 7. Inflating



**You have to inflate the tire carefully, following below instructions strictly. Pls note there is no protection device on designing of the tire changer for the safety of the operator on the machine or surrounded machine if the tire explode suddenly. .**

**⚠ DANGER**

- A burst of tire can cause serious injury or even death of the operator.
- Check carefully that the wheel rim and the tire are of the same size.
- Check the state of wear of the tire and there is no defects before beginning the inflation stage.
- Inflate the tire with brief jets of air, checking the pressure frequently.
- All our tire changers are limited to a maximum inflating pressure of 3.5 bar in any case never exceed the pressure recommended by the manufacturer.
- keep your hands and body as far as possible from the tire in inflation stage.

## 7. 1 Inflating tire with nozzle

Standard semi-automatic tire changer is equipped with pressure nozzle to inflate a tire.

Follow below instructions to inflate a tire:

- Connect the nozzle fitting to the tire valve.
- Check the wheel rim and the tire are of the same size.
- Check the wheel flange and rim are with enough lubrication.
- Press the nozzle trigger, in this stage, control the inflating pressure, until the tire fits to the rim completely.
- Continue to inflate the tire and check the inflating pressure frequently, never to exceed the pressure indicated by the manufacturer.

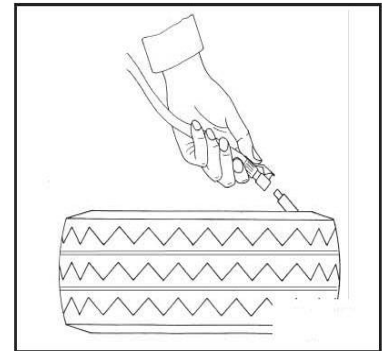

Pic.13

**⚠ DANGER**

### Danger of burst:

- Never to exceed the pressure indicated by the manufacturer: 3.5bar
- Remove the tire from the turntable, if you need more inflating pressure, place the tire in special protection cage to continue the inflation operation.
- Never to exceed the maximum inflation pressure.
- Keep your hands and body as far as away from the tire
  - Only professionals are allowed to use the machine. Other people are not allowed to use or approach the machine during the inflation stage

## 8. Relocate

**Forklifts are needed to move semi-automatic tire changer.**

- Disconnect the electric power supply and compressed air system.
- Insert the crowbar on one side bottom of the tire changer, get the machine off the ground, and then insert the fork, lifting it up.
- Place the tire changer in new position.

**Note: Location of the new place must comply with national safety regulations.**

## 9. Storage

If the tire changer need to be stored for some time, pls follow below instructions: Disconnect all energy supplies and lubricate the slide of the clamps on the turntable to prevent oxidation.

## 10. Scrap

Make sure all energy supplies are disconnected when deciding to scrap the equipment.

- All nonferrous metals and nonmetals shall be disposed of as scrap in accordance with relevant laws and regulations.
- Process the oil inside the machine at the place specified by applicable law.
- Discard the remaining steel.

## 11. Maintenance

### 11.1 Warning

Untrained people is not allowed to carry out maintenance work.

- Regular maintenance as described in the instructions for correct operation and long lifetime of the tire changer.
- If maintenance is not carried out regularly, the operation and reliability of the machine may be compromised, thus placing the operator and anyone else in the vicinity at risk.



**Before carrying out any maintenance work, disconnect the electric and pneumatic supplies. Moreover, if it is necessary to break the bead load less 3-4 times in order to let the air in pressure go out the circuit.**

- Damaged parts must be replaced exclusively by expert personnel use the manufacturer's spare parts.
- It is forbidden by national safety regulation to disassemble and replace safety devices(safety valves and regulating valves)



In particular, the manufacturer shall not be liable for any damage caused by users using parts of other manufacturers or damage by disassembly and damage of safety devices.

## 11.2 maintenance

- **Clean the turntable once a week with diesel fuel so as to prevent the formation of dirt, and grease the clamp sliding guides.**

- **Perform the following maintenance work once a month:**

- Control the oil level of oil-water separator. If the level is low, screw off the oil cup F before adding. Use only oils specified by ISO HG with viscosity ISO VG32. Such as: ESSO Febis K32, MOBIL Vacouline 1405, KLUBER32 (Pic.15)
- Step pedal bead breaker 3-4 times, checking if some oil filled in oil cup F. If not, adjusting screw D. (Pic.15)

**Note:** After the first 20 days of work, retighten the clamp tightening screws and screws on turntable slides. (Pic.16)

**Note:** In the event of a loss of power, check that the drive belt is tight or not as follow:

Disconnect power supply before operation.

- Remove the left side body panel of tire changer, unscrewing the four fixing screws.
- Tighten the drive belt by means of the special adjusting screw X on the motor support. (Pic.17)

**Note:** If the working head is not locked or cannot be stopped 2mm above the rim, the locking plate of the operating arm shall be adjusted as shown. (Pic. 18).

**Note:** For cleaning or replacing the silencer of opening/closing clamps(G), proceed as follows (see Pic.19):

- 1) Remove the left side panel of the machine body by unscrewing the four fixing screws.
- 2) Unscrew the silencer put on pedal system V, on the clamp G opening/closing pedal.
- 3) Clean by a jet of compressed air, or if damaged, replace by the same spare parts.

**Note:** For cleaning or replacing the silencer of bead breaker R, see pic. 20, and proceed as shown on previous point 1&3.



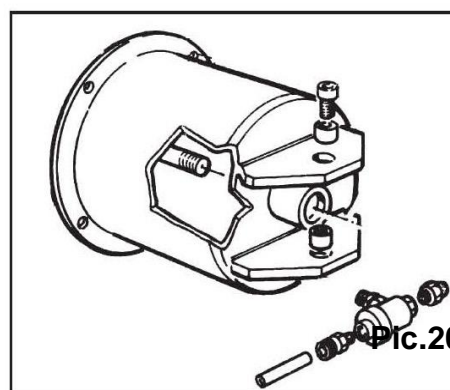
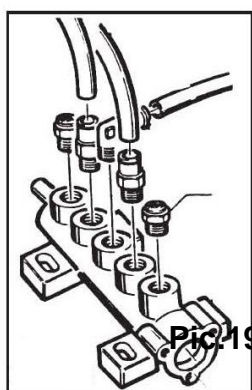
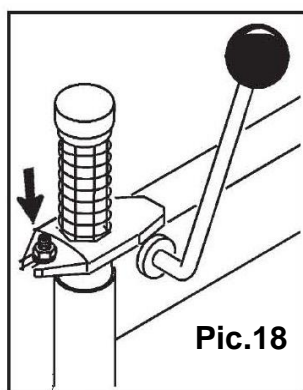
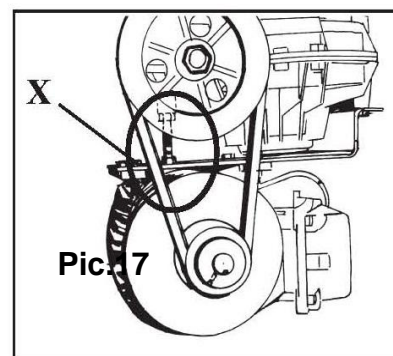
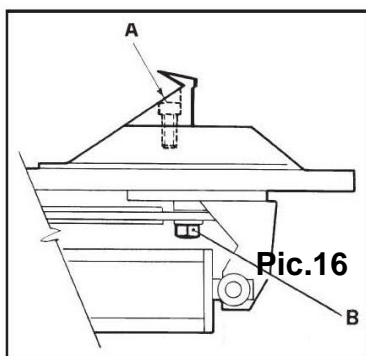
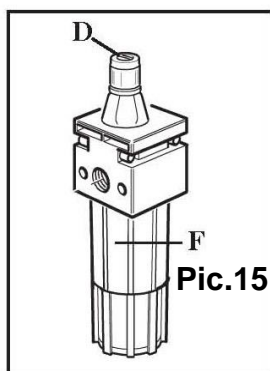

## 12、 Trouble shooting

trouble	cause	troubleshooting
Turntable rotates only in one direction	universal switch is damaged	universal switch
Turntable doesn't rotate	1、 Belt is damage 2、 universal switch is damage 3、 motor trouble	1、 replace the belt 2、 replace the universal switch 3、 replace motor
Turntable doesn't work	Belt loose	Adjust belt tension
clamp open/close slowly	1、 Silencer trouble	Clean or replace
turntable doesn't lock the rim correctly	1、 Clamp is damaged 2、 Cylinder of turntable is damaged	1、 Replace clamp 2、 Replace the sealing ring of cylinder
The working head touch the rim when operation	1、 Locking place position is incorrect or damaged 2、 Turntable locking screw loose	1、 Adjust or replace locking plate 2、 Tighten screw
Pedal should not be located in working position	Return spring damage	Replace the return spring
Bead breaker operation difficult	1、 Silencer trouble 2、 Cylinder sealing ring of bead breaker is damaged	1、 Clean or replace the silencer 2、 replace the sealing ring

### 13. Technical data

Feature	Technical data
Clamp rim size outside	9"-19"
Clamp rim size inside	13"—25"
Max. wheel diameter	1070mm( 39")
Max. tire width	350mm( 14")
Pressure bead breaker ( 10bar )	3100kg
Working pressure	10bar(145psi)
Max. inflation pressure	3.5bar(50psi)
voltage	230/400V 3ph
power	0.75/1.1kw
Max. shaft torque	1200Nm
Machine size	1160 X 900 X 1120
Net weight	Standard machine type195kg GT machine type213kg
Level of noise	<75dB(A)

### 14. Circuit diagram and pneumatic system diagram

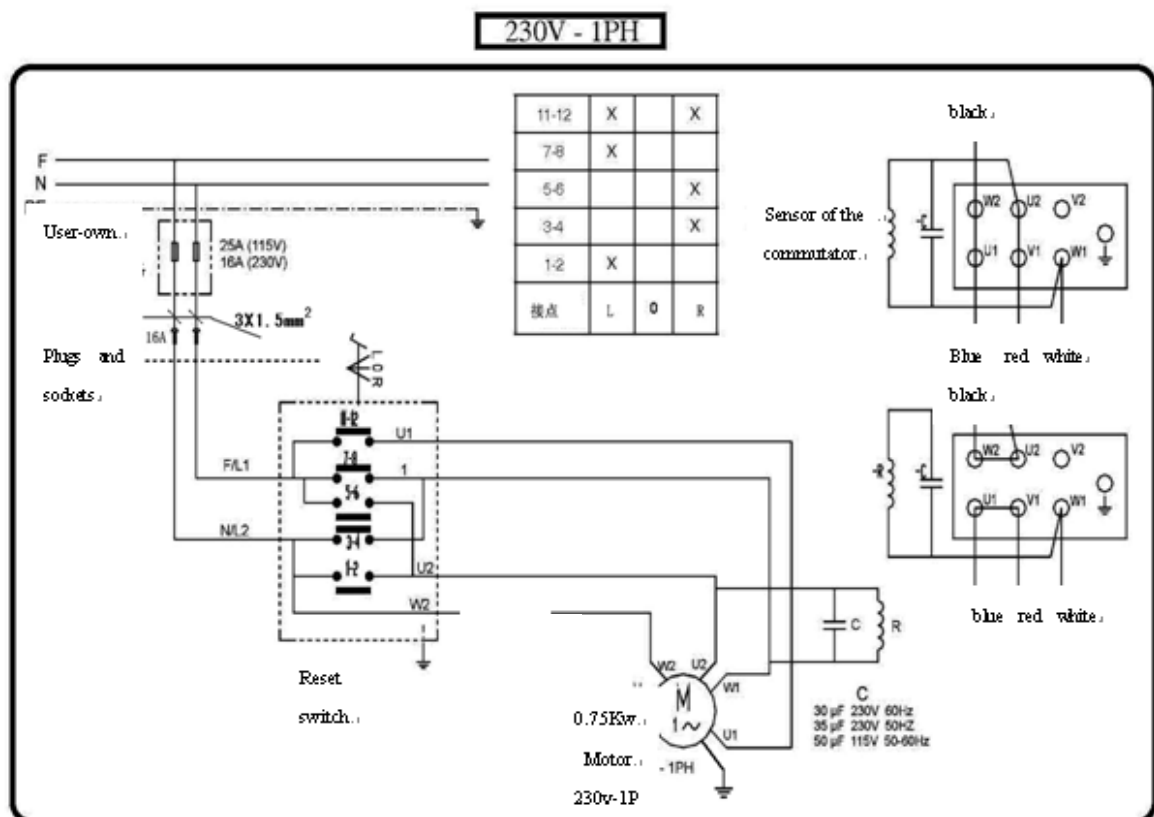

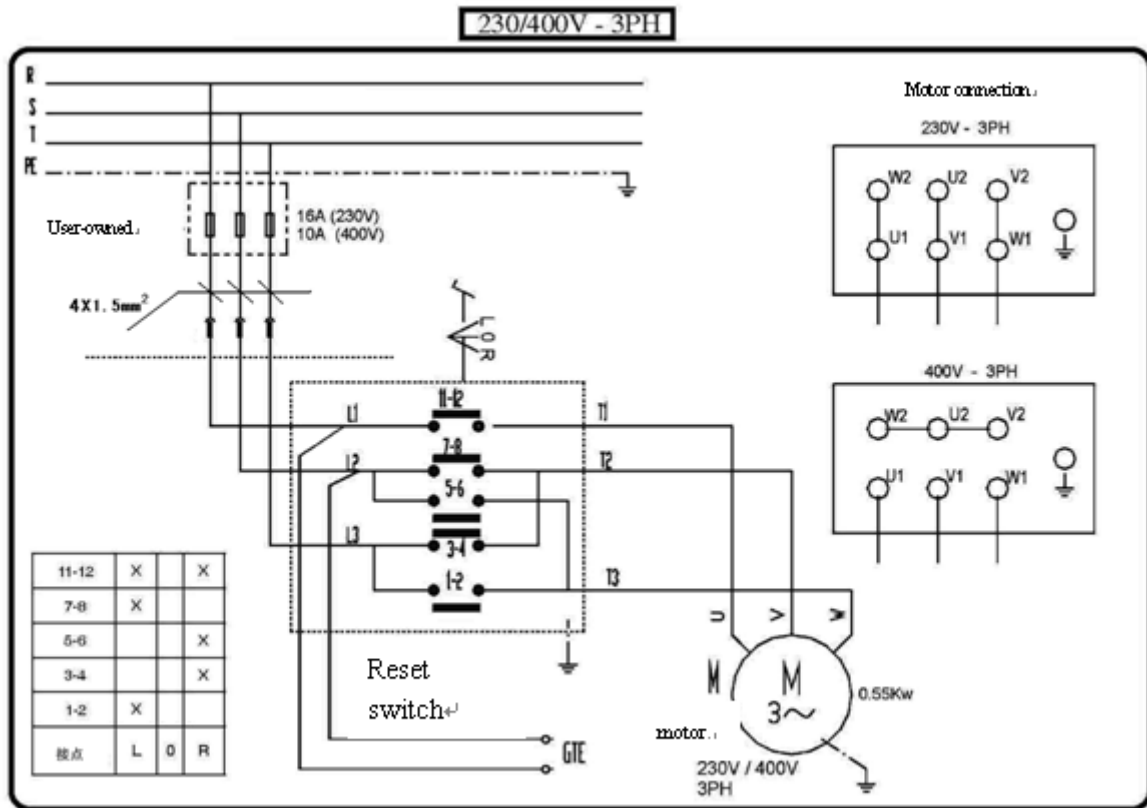

standard pneumatic system diagram

